

**1. Part Number:** A736-1000

**2. Photograph:**

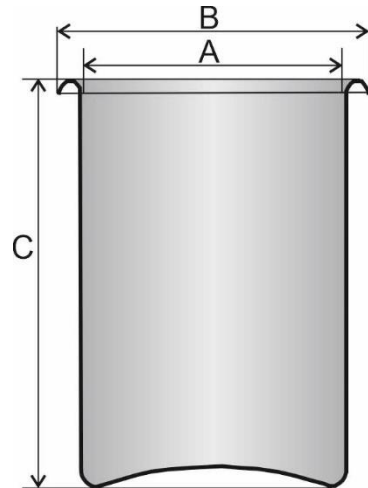

### 3. Product Information:

|                                 |   |
|---------------------------------|---|
| Description:                    | Stainless Beaker 1000ml   |
| Method of Construction:         | Crevice free, all welds ground and polished   |
| Material of Construction:       | 316L Stainless Steel  |
| Surface Finish:                 | Better than 0.5 microns Ra  |
| Nominal Volume:                 | 1000ml  |
| Dimensions:                     |   |
| A - Internal Diameter:          | 99mm  |
| B - Nominal Overall Diameter:   | 110mm   |
| C - Nominal Height:             | 150mm   |
| Wall Thickness                  | 1.2mm   |
| Nominal Weight:                 | 480g  |
| BSE/TSE statement:              | All polishing compounds used in the manufacture of this product are free of animal products |
| Recommended Storage Conditions: | Dry and ambient temperature   |

### 4. Approval:

Signed:



Name: Kuldeep Flora

Position: Quality Manager

Date: 30-Jun-21