

This drawing and/or any technical information relating to it is issued in strict confidence and may not be reproduced or used for manufacture without written permission. Sign recall of which it is the users responsibility to seek confirmation of any dimensions and production tolerances.

ENGRAVING DETAILS

ALL CHARACTERS TO BE RAISED 0.30
 NUMBERS TO BE 3.0 HIGH
 LETTERS TO BE 5.0 HIGH

THIS AREA TO BE INSERTED ON THE TOOL
 TO ALLOW THE CUSTOMERS NAME
 TO BE ENGRAVED IF REQUESTED

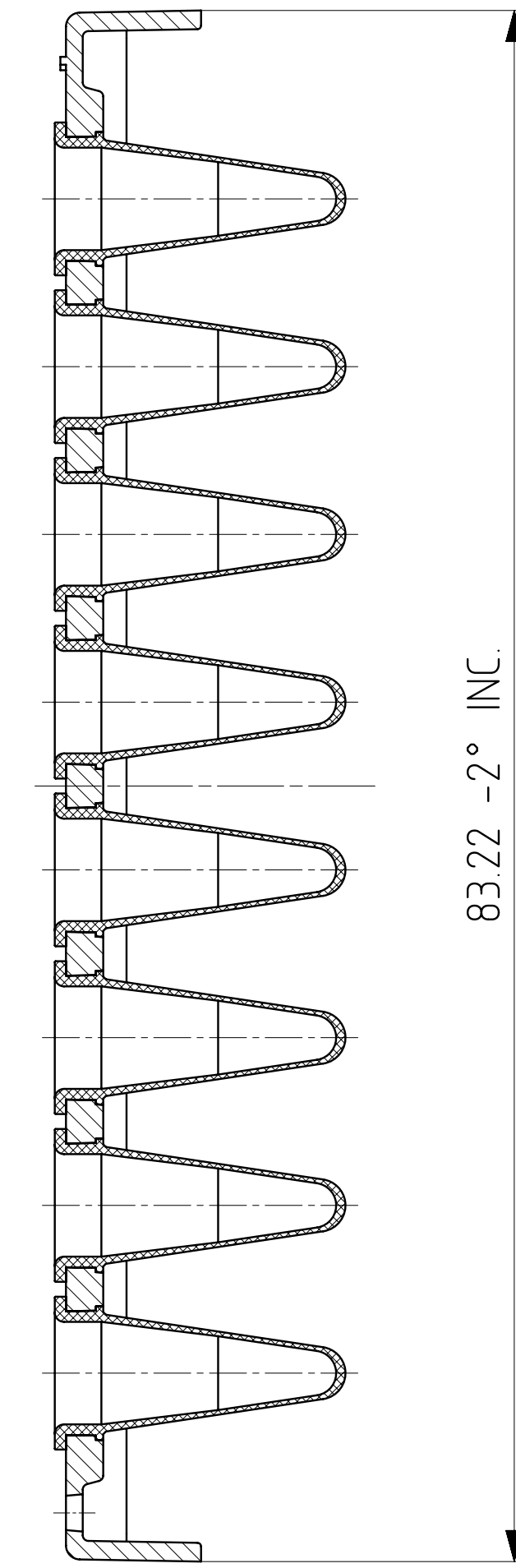
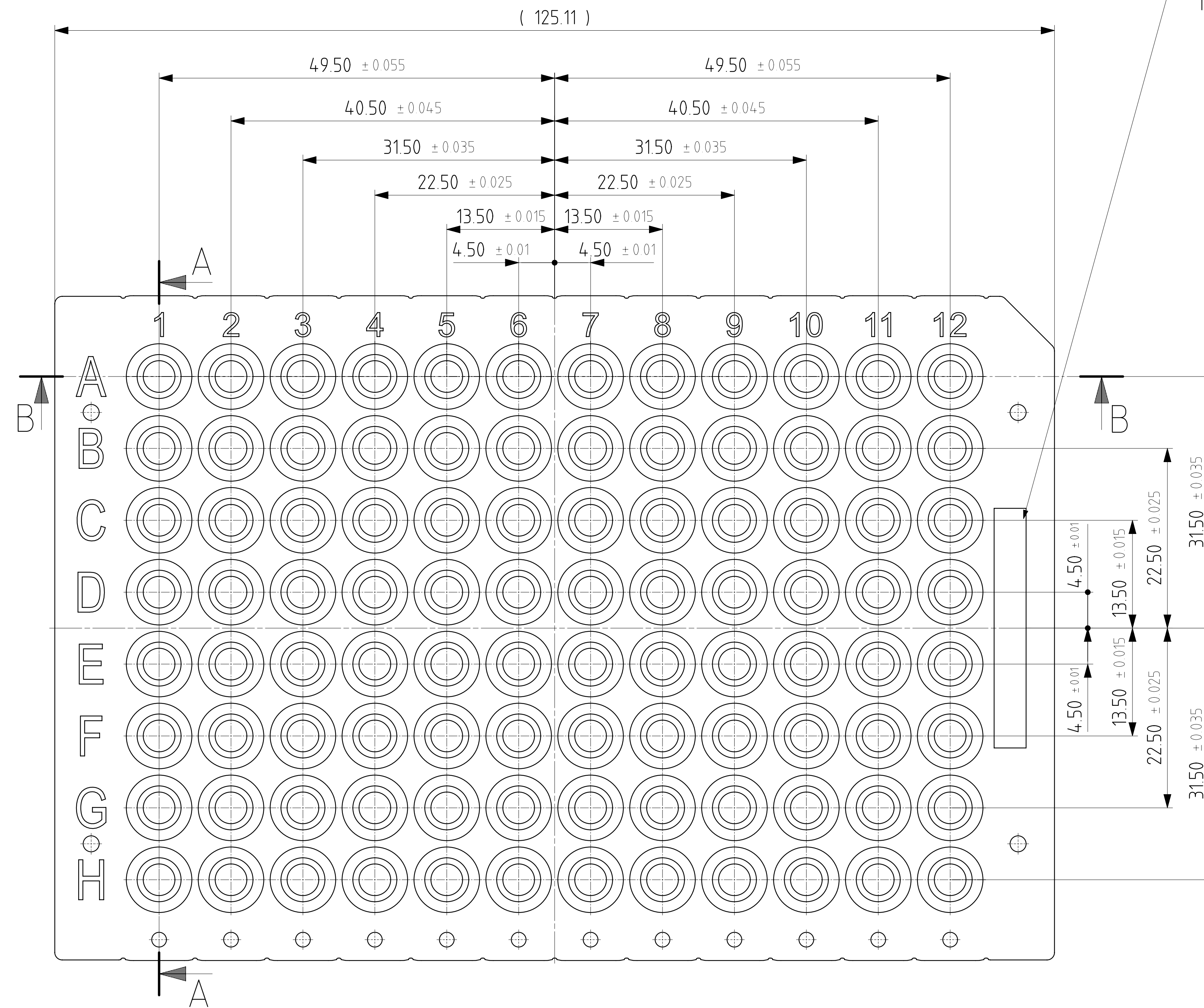
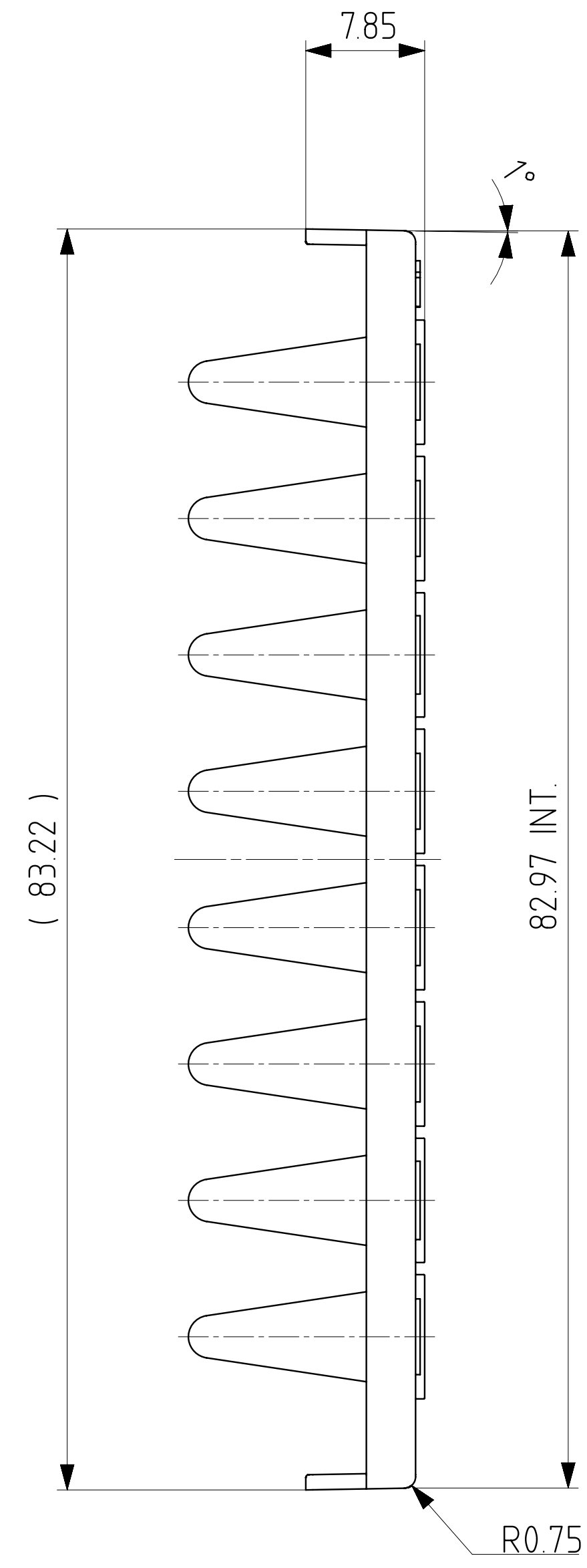

SECTION A-A

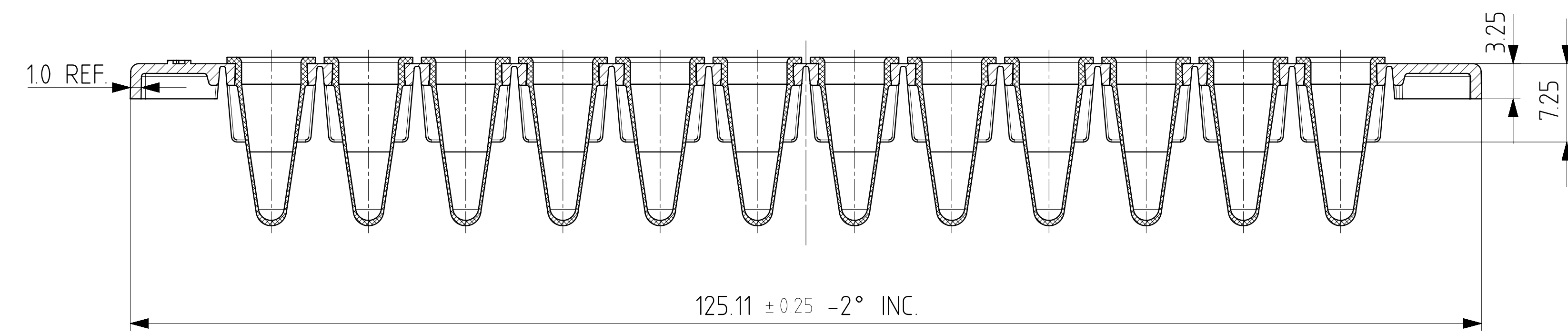

SECTION B-B

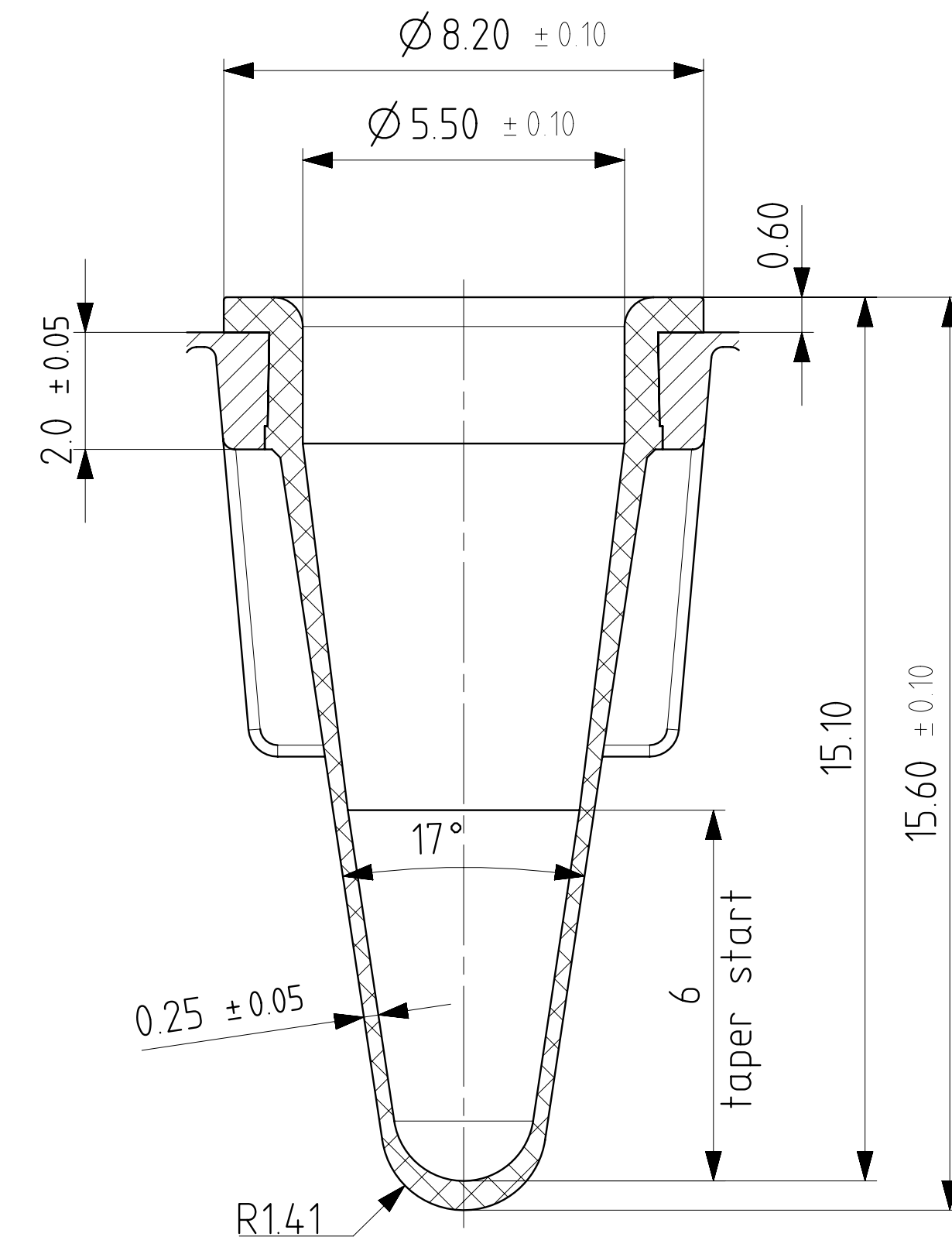

VIAL FORM 96 pos
 SCALE 10:1

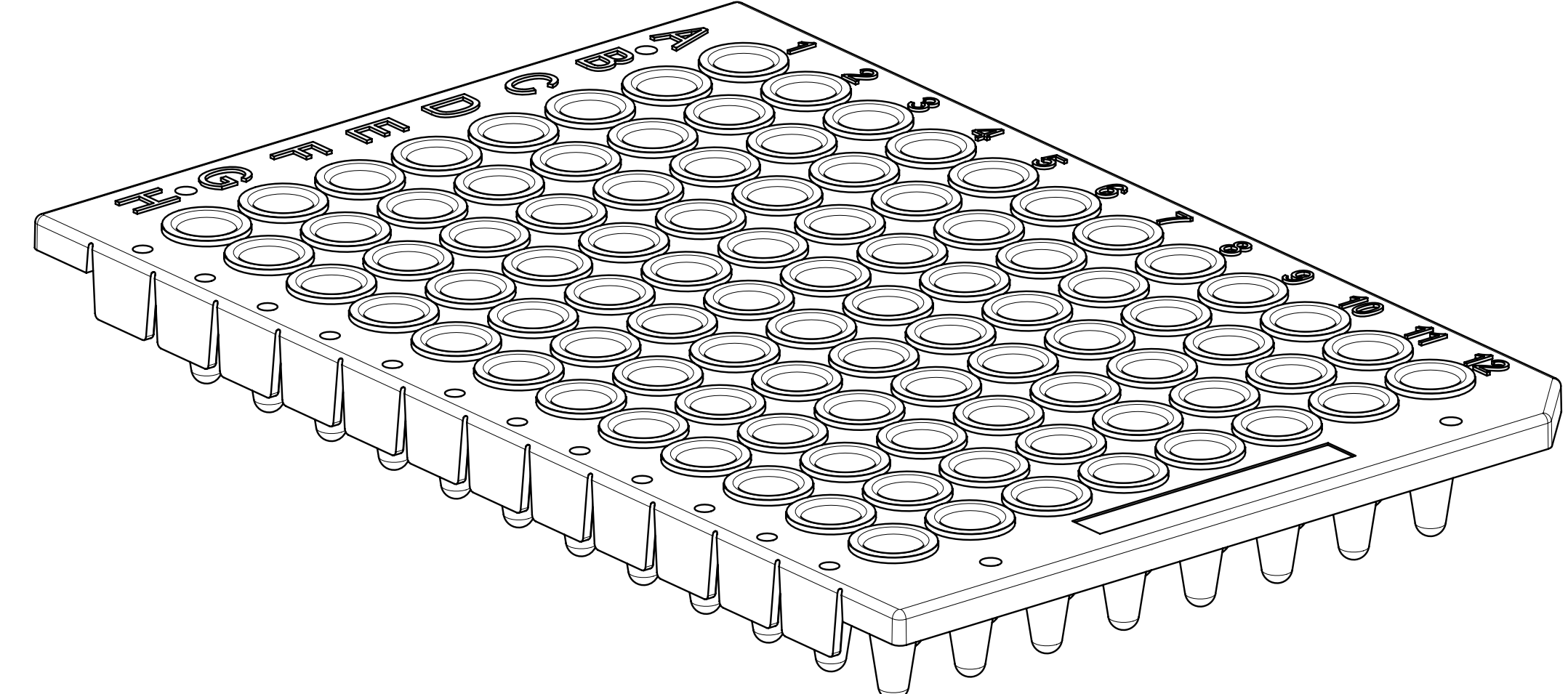

ISSUE	DATE	AMENDMENT	ISSUE	DATE	AMENDMENT



 DO NOT SCALE IF IN DOUBT ASK	CUSTOMER CUSTOMER DRG No MATERIAL FRAME: polycarbonate, TUBES: polypropylene	DRAWN ZOLTAN E. DATE 21.10.2013 CHECKED JAMES B.	TITLE FRAMEstar ■■■ BREAK-A-WAY (short tube version) MARKETING DRAWING
	TOLERANCES GENERAL TOLERANCES (UNLESS OTHERWISE STATED) 0 ±0.20 0.05 ±0.10 0.10 ±0.05 ANGULAR ±0.30° (ALL DIMENSIONS IN MILLIMETRES)	DATE SCALE	DRAWING No 4ti-1200 SHEET No 1 OF 1 ISSUE C