

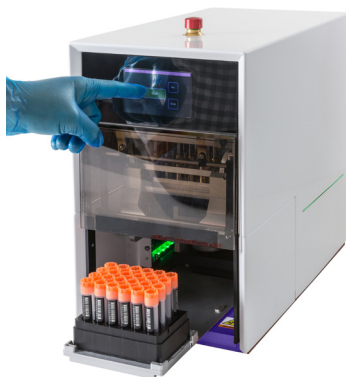

IntelliXcap Technical Specification

IntelliXcap™ is a next-generation capper and de-capper, engineered for increased throughput, ease of use and high system reliability, making the system ideal for any laboratory managing compound libraries or biological sample stores.

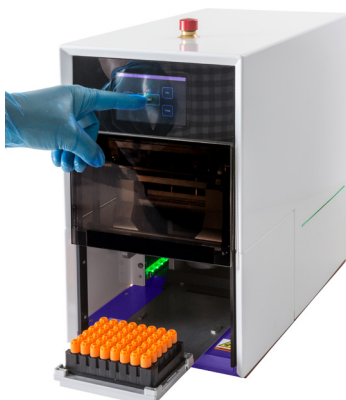

Key Features

Advanced Automation Means Increased Throughput

- IntelliXcap is extremely fast and works with multiple sample storage tube types from a range of tube manufacturers in 24, 48 and 96 format
- The only 96-format full rack capper and de-capper capable of de-capping a complete rack of 96 tubes in as little as 20 seconds
- Automation and high speed reduces sample handling time, increasing sample throughput workflow
- Ideal for medium to high-throughput laboratories managing compound libraries, biobanks or other biological samples

Compact, Modular Design Means Ultimate Flexibility

- IntelliXcap features the unique, fully automated, interchangeable cartridge cap driver system
- Cartridge allows format change between different tube types in less than 2 minutes
- Simply by fitting the relevant cartridge, IntelliXcap is compatible with all Azena sample storage tubes, as well as sample storage tubes from Thermo Matrix, Thermo Nunc, LVL, Micronic
- Cartridge is available for both internal and external thread screw-cap tubes
- No need for specialist intervention to change cartridge drivers
- Control is via a quick installation, easy-to-use touch panel

Easy to Use, Easy to Integrate

- Quick installation, easy-to-use touch panels bring instant control
- Wide operating temperature range of 5°C to 40°C
- Electric torque control means less persistent wear on cap drivers
- Easily integrated, sample rack stage extension facilitates fully automated workflow integration



IntelliXcap Technical Specification

IntelliXcap Weights and Dimensions

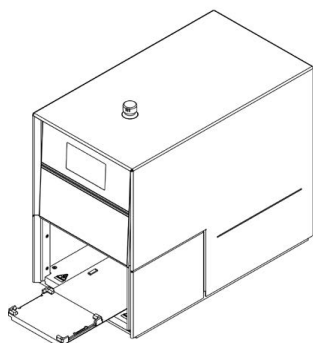

Parameter	IntelliXcap 24	IntelliXcap 48	IntelliXcap 96
System Height	386.2mm	386.2mm	320mm
System Width	256mm	256mm	256mm
System Depth	464.4mm	464.4mm	464.4mm
Stage Height	31.7mm	31.7mm	31.7mm
Stage Width	138mm	138mm	138mm
Stage Distance (when ejected)	136.5mm	136.5mm	136.5mm
System Weight	27.96kg	28.74kg	26.80kg

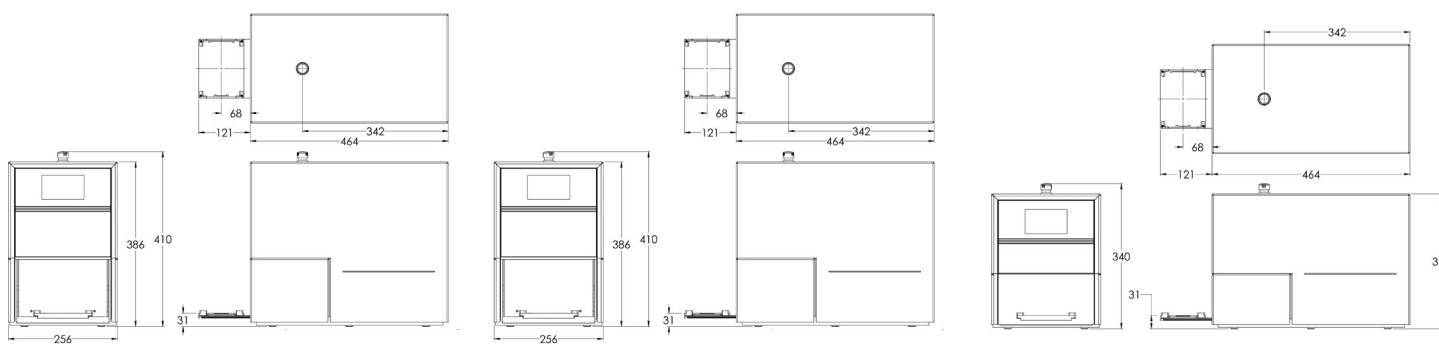

IntelliXcap 24 Channel

IntelliXcap 48 Channel

IntelliXcap 96 Channel

Extended Stage for Automation

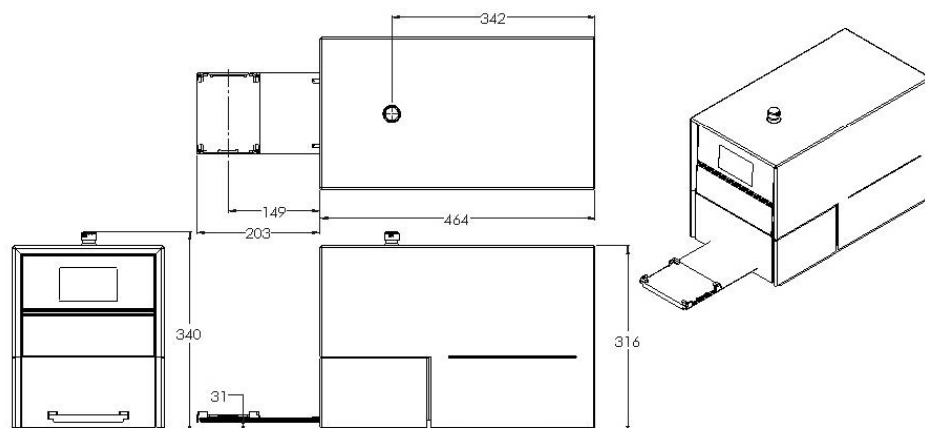

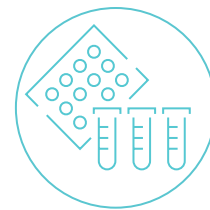

IntelliXcap Technical Specification

Environmental Requirements

Parameter	Specification
Temperature - Transport and Storage	15 - 40° C (59 - 104° F)
Temperature - Operation	0 - 40° C (32 - 104° F) Using the IntelliXcap in an environment where the temperature is 40° C (104° F) or higher for an extended period may cause the screen contrast level of the monochrome LCD to decrease from its original level of brightness
Storage Humidity	10 - 70% RH Wet bulb temperature 39° C (102° F) max, no condensation
Relative Humidity	10 - 90% RH Wet bulb temperature 39° C (102° F) max, no condensation
Storage Lighting	All external surfaces are resistant to UV-light. Over time, UV-light might affect LCD panels: LCD screens may fade
IP 30	Protection against small foreign bodies >2.5mm (e.g. a screwdriver), and no protection against water
Dust	0.1mg/m ³ and below (non-conductive levels)
Pollution Degree	For use in Pollution Degree 2 environment Decontamination treatment with Hydrogen Peroxide Gas needs to be avoided as it will damage the electronic parts

Electrical Requirements

Parameter	Specification
Supply Voltage	100 - 120 VAC 1/N/PE /220 -240 VAC 1/N/PE Use IEC 320 plugs only Ground must be connected at all times
Maximum Power Consumption	500 W
Idle Power Consumption	100 W
Supply Frequency	The machine operates below the noise emissions level: <70 dB(A)
Fuses	Two fuses: 100 - 120V AC 5A fuse 220 - 240V AC 5A fuse
Insulation Resistance	Not less than 1MΩ at 1,000V Phase 1 = 50GΩ Neutral = 50GΩ
UI Connection	RS232 cable
Speed	>20 seconds per Rack
Air Requirement	N/A
Air Input Pressure	N/A

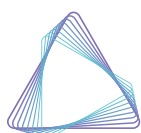



IntelliXcap Technical Specification

IntelliXcap Performance

Decapping Torque(*)	Specification
IntelliXcap 24	Up to 30N/cm
IntelliXcap 48	Up to 30N/cm
IntelliXcap 96	Up to 9.5N/cm
Recapping Torque(*)	
IntelliXcap 24	Up to 15N/cm
IntelliXcap 48	Up to 15N/cm
IntelliXcap 96	Up to 5.5N/cm

(*)Note: Not a user-configurable parameter

Ordering Information

46-8012	Azenta IntelliXcap 96 96-Format Screw Cap Tube Rack Decapper/Capper with automatic glide rail for integration, includes 1 cartridge of choice, please quote tube type when ordering. Suitable for all Azenta tubes and almost all other brands with Azenta cartridges
46-8011	Azenta IntelliXcap 48 48-Format Screw Top Tube Rack Decapper/Capper with automatic glide rail for integration, includes 1 cartridge of choice, please quote tube type when ordering. Suitable for all Azenta tubes and almost all other brands with Azenta cartridges
46-8010	Azenta IntelliXcap 24 24-Format Screw Top Tube Rack Decapper/Capper with automatic glide rail for integration, includes 1 cartridge of choice, please quote tube type when ordering. Suitable for all Azenta tubes and almost all other brands with Azenta cartridges
46-8112	Azenta IntelliXcap Extended Stage for Automation. Suitable for IntelliXcap 24, IntelliXcap 48 and IntelliXcap 96



AZENTA
LIFE SCIENCES

[azenta.com](https://www.azenta.com)

© 2022 Azenta US, Inc. All rights reserved. All trademarks are property of Azenta US, Inc. unless otherwise specified. 42017-SD-2 0222