

Instruction Manual

Platemax[®]

SEMI-AUTOMATIC PLATE SEALER



Catalog Numbers:

HS-1120

HS-1230

Axygen Scientific.

33210 Central Avenue,
Union City, CA 94587, USA
Tel: +510-494-8900
Fax: +510-494-0700
E-mail: axgsales@corning.com
Web Site: www.axxygen.com

Operating Conditions

The PlateMax is designed for use under the following conditions:

- Indoor use only
- Ambient temperature range of 15°C ~ 30°C
- Maximum relative humidity of 80%
- Storage temperatures of 0°C ~ 60°C
- Product should be placed on a flat surface at least 30.5 cm (12") from walls, 122 cm (48") from ceilings, and 30.5 cm (12") from other equipment.
- Pollution Degree 2: Any foreign matter that may accumulate on or within the product during normal use is not electrically conductive.
- Installation Category II: Product is designed for connection to an electrical branch circuit inside a building with main supply voltage fluctuations not exceeding $\pm 10\%$ of the nominal voltage.

Safety Information

This instruction manual contains important operating and maintenance instructions which must be read, understood, and followed by the product user. Failure to use this product according to this instruction manual may degrade or defeat the protection normally provided by this product. Read this instruction manual prior to product use and keep this instruction manual for future reference.

Product Symbols



Caution - Risk of danger: Cautions that there is material in the instruction manual which must be read, understood, and followed in order to preserve product safety features.



Hot Surface: Cautions that the platen and other internal components can be too hot to touch

Warnings

Personal Injury

- Do not use this product in a manner other than as stated in the Operating Conditions section of this manual as the protection provided by the equipment may be impaired.
- This product is designed for use in laboratory environments by persons knowledgeable in safe laboratory practices.
- Always wear safety glasses and other appropriate protective equipment when operating this product.

Electric Shock

- This product must be connected to a grounded power outlet for safe functioning.
- Use only the power cord supplied with the product.
- The power cord is the device available for full disconnect from mains input.
- Position the product for use so that the power cord can be easily disconnected without having to move the product.
- Disconnect the power cord before moving or cleaning the unit.

Product Damage

- Keep the product dry and clean.
- Do not immerse the product in liquid for cleaning.
- These units are not explosion or spark proof.
- Do not operate this product near volatile or flammable materials.

Specifications

Dimensions (W x D x H):	6.75 x 12.75 x 14.25 inches (171 x 324 x 362 mm)
Weight:	27 Lbs/12 Kg
Sealing Temperature:	OFF, 100°C to 190°C (increments of 1.0°)
Temperature Accuracy:	+/- 1.0° C
Temperature Uniformity:	+/- 1.0° C
Sealing Time:	0.5 to 10 sec. (increments of 0.1 sec)
Compatible Plate Materials:	PP (Polypropylene) PS (Polystyrene)
Compatible Plate Types:	Standard Assay Plates Deep-Well Storage Plates PCR Plates: skirted, semi-skirted, non-skirted
Maximum plate height:	45mm
Compatible Sealing Film Types:	Foil-polypropylene laminate Clear polyester-polypropylene laminate Clear polymer Thin clear polymer Foil-laminate Foil
Electrical Requirements:	AC100V ~ 120V, 50/60Hz, 400 Watts, 3.15A AC220V ~ 240V, 50/60Hz, 400 Watts, 2A

Introduction

The PlateMax is a semi-automated heat sealer, used for sealing of a wide variety of microplates to store samples, prevent evaporation and minimize contamination.

It thermally bonds seals and foils to a wide variety of microtiter, cell culture, PCR and deep well plates. The digital temperature and timer control allows user selection of parameters for combinations of plates and seals.

A plate sensing system allows the PlateMax to provide uniform force, transferring heat evenly to the sealing surface whether using shallow PCR plates or deep well plates.

Getting Started

1. Unpack the instrument carefully and place on a level stable surface that can withstand its weight. Do not block ventilation openings on the back.
2. Remove and identify all components from the box.
 - Power cord
 - Seal Frame
 - Plate Sealer
 - HS-PCR-ADAPTER – PlateMax
 - HS-FLT-ADAPTER – PlateMax
 - Instruction Manual
3. Remove the protective plastic bag and any protective film.
4. Plug the power cord into the back of the instrument, and plug the other end into a properly rated outlet. Confirm that the voltage rating listed on the instrument is properly labeled to 110V or 230V as required.
5. Switch the main power to 'ON'.
6. The front control panel display will illuminate.

Display Overview



1. **SEAL TEMP** – Indicates sealing platen temperature
2. **SEAL TIME** – Displays sealing time
3. **STATUS** – Shows Heating, Cooling, Ready or Error states

Unit Overview

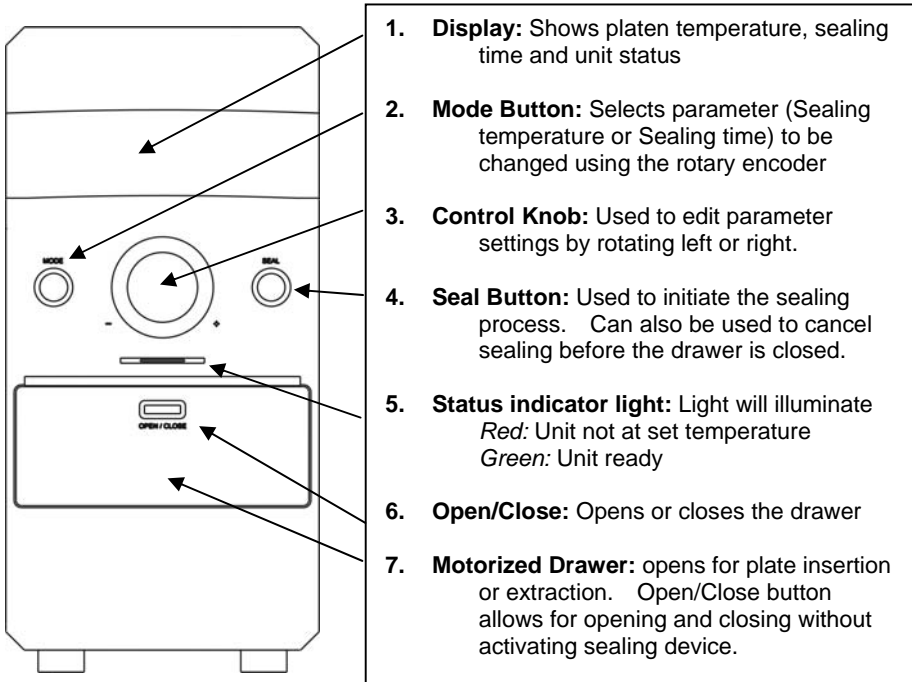

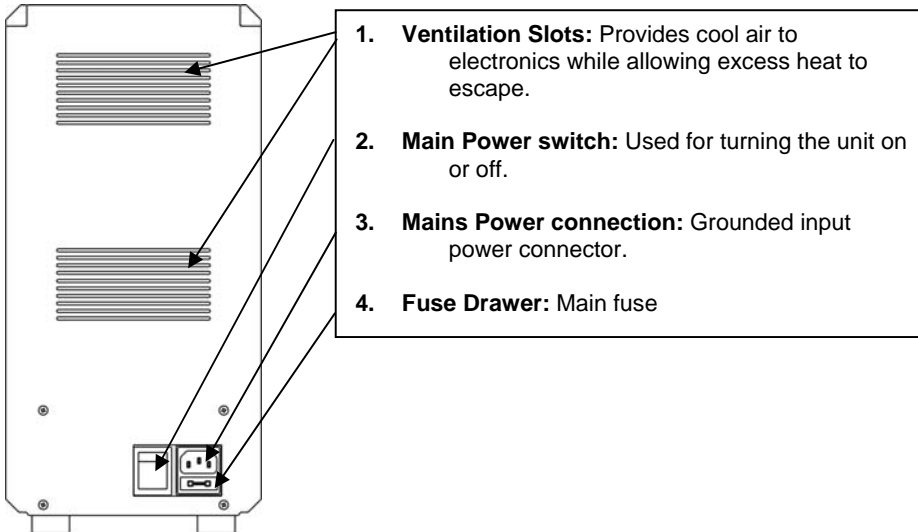

Operation

Note: the PlateMax Plate Sealer should be used only with Microplates and Seals that are designed for heat sealing. It is the user's responsibility to confirm that the consumables being used are appropriate for the application.

Proper heat sealing of Microplates requires the proper temperature and time settings. Contact your consumable manufacturer for recommended time and temperature parameters.

It is commonly required to try different temperature and sealing time settings to optimize the sealing of different types of plates. Many polypropylene plates and sealing films seal well using a sealing temperature of 165°C and sealing time of 4.5 seconds.

After installing the unit, you will need to power it up using the switch in the back and choose your sealing settings.

Set the Temperature

Press the MODE button until the "Seal Temp" text is flashing. Use the control knob to adjust the display to the desired temperature.

Press the Control knob or wait 10 seconds to set the selected temperature.

When a temperature is set above the current temperature of the heating platen, the display will show "Heating" and the Status indicator LED above the door will flash red.

When the temperature of the heating platen reaches the set temperature, the display will show "Ready", and the indicator LED will be a steady green.

It is recommended to leave the drawer closed, without a sample plate on the drawer while the platen is heating up. This will allow the unit to heat to the set temperature more quickly.

Set the Time

Pressing the MODE button until the "Seal Time" text is flashing. Use the control knob to adjust the display to the desired sealing time.

Press the Control knob or wait 10 seconds to set the selected time.

Using Plate Adapters

Axygen offers accessory adapters that may be required for optimal sealing of certain multi-well plate configurations.

96 well plate side

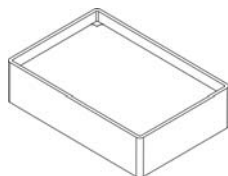
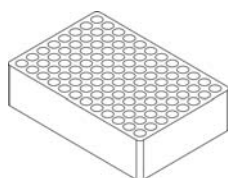

384 well plate side

HS-PCR-ADAPTER – PlateMax adapter for sealing assay and PCR plates

One side (96 holes) accommodates 96-well plates and the other side accommodates 384-well PCR plates.

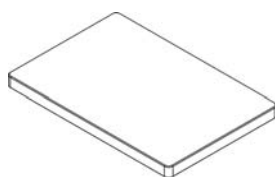

HS-FLT-ADAPTER – PlateMax support block for assay and storage plates

Thin block that is designed to support the center portion of assay plates and storage plates.

Using the Seal Frame

A sealing frame is provided with the unit to assist in securing the thermal seal in proper position prior to sealing the plate. This ensures proper positioning of the seal and prevents any curling or undesired movement of the thermal seal prior to the sealing process.

After loading the plate and placing the seal on top of the plate, the frame is then lowered over the thermal seal and onto the plate. Tabs at either end of the frame secure the thermal seal in place. There are 4 metal posts around the plate which serve as indexing points for the frame.

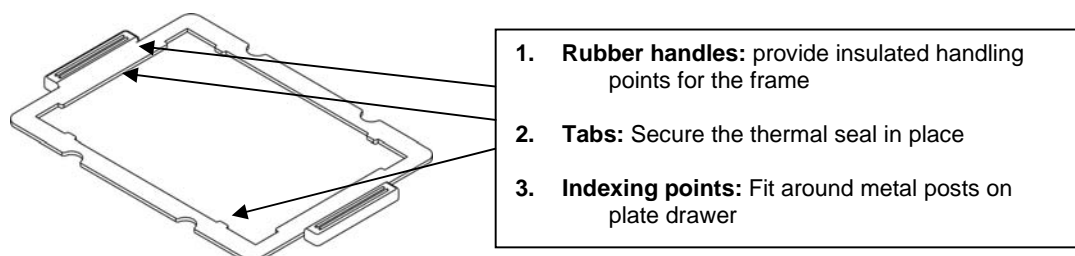

Sealing a Plate

Based on seal and plate being used select the time and temperature using the Mode button and Control knob. Consult seal manufacturer for recommended settings. If the plate you are using will require an adapter place it into the recessed area in the middle of the drawer. This will prevent the adapter from shifting position during sealing.

Next, position your plate on top of the adapter or directly in drawer. Confirm that the plate is centered and flat. Next lay the thermal seal on top of the plate, again being sure that it is centered.

Note: Make sure the seal is placed with the sealing side on the plate. If the seal is placed upside down, it will stick to the hot platen, and this will require cleaning of the platen (see: Accessing and Cleaning the Heating Platen).

Once the thermal seal is placed, place the seal frame on top to prevent the seal from shifting position. Depending on the settings chosen, the unit may require some time before the heating platen has reached the desired temperature. After the settings are entered and the status light is green, the unit is ready for sealing.

Keep hands and fingers clear of the drawer and press the Seal button. The drawer will close automatically, the plate will be sealed and the drawer will open for removal of seal frame and plate.

Sealing a Plate

1. Set Sealing temperature and time.
2. Insert Adapter (if required).
3. Place plate in drawer.
4. Place seal on top of plate.
5. Place sealing frame on top of seal.
6. Press Seal when light is green – *drawer will close, seal the plate and open automatically*
7. Remove sealing frame.
8. Remove sealed plate.

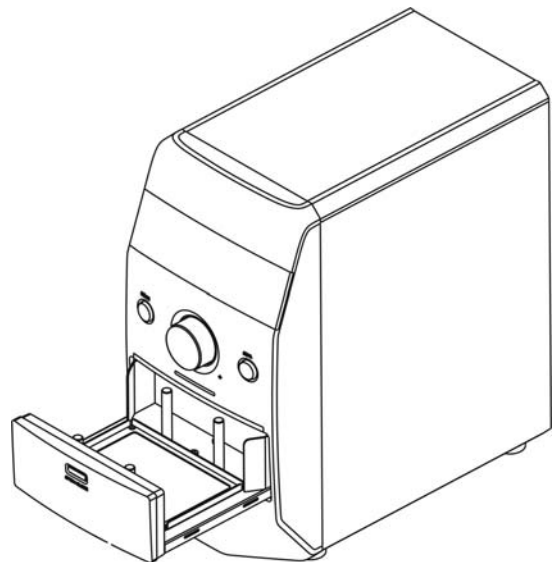

Accessing and Cleaning the Heating Platen

In the event that a seal becomes stuck to the heating platen, the below steps will allow you to clean the platen.



Warning – The heating platen can reach temperatures in excess of 190° - allow the unit to cool for at least 1 hour before attempting to clean the platen.



Warning – be sure to turn the unit off and unplug it from the power source before attempting to clean the platen

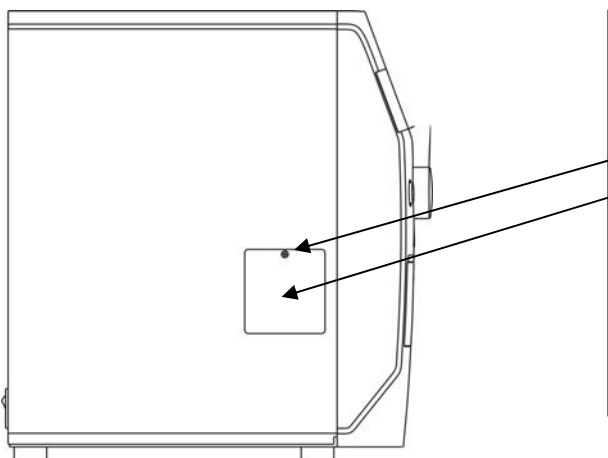

Cleaning the Heating Platen

1. Open the drawer of the unit.
2. Power the unit down and unplug it.
3. Allow to cool for at least 1 hour.
4. Using a Phillips head screwdriver, remove the retaining screw for the access door.
5. Remove the access door.
6. Clean the platen by hand using a plastic putty knife. Alcohol may be used to remove any residue.
Do not use a metal tool (i.e. screwdriver) to scrape the platen as this could gouge the surface.
7. Replace the access door and screw.

Power Save Mode

If the unit is left on but inactive for long periods, it will enter a power saving mode. These modes are described below.

Display	Time frame	Temperature
STND_BY	1 hour of inactivity	60°C
PWRSAVE	3 hours of inactivity after entering STND_BY mode	Ambient (heater off)

Troubleshooting and Error Codes

Error	Possible Cause	Solution
Plates not sealing correctly.	Insufficient sealing time	Check with sealing film manufacturer for recommended sealing time and temperature.
	Sealing temperature too low.	
	Top of plate is not flat.	
Sealing film is curling and moving out of position	Temperature difference and electrostatic charge affecting seal	Use Sealing frame to secure seal in place.
Sealing film is sticking to platen.	Foreign material stuck to platen.	Follow procedure for cleaning heating platen.

Code	Possible Cause	Solution
Error 1	Tray Motor or Switch failure	Call Axygen Service.
Error 2	Tray Motor or Switch failure	Call Axygen Service.
Error 3	Heater Motor or Switch failure	Call Axygen Service.
Error 4	Heater Motor or Switch failure	Call Axygen Service.
Error 5	Heater is not working or temperature sensor (PT-1000) failure	Call Axygen Service.
Error 6	Heater PCBA failure	Call Axygen Service.
Error 8	Heater is not working or temperature sensor (PT-1000) failure	Call Axygen Service.
Error 9	Safety door/housing switch activated during drawer operation.	Reboot the unit.
	Foreign object stuck between tray door and tray plate	Turn off the unit. Remove the foreign object and reboot the unit.

Warranty Statement

The PlateMax Semi-Automated Plate Sealer and associated accessories are covered by standard Axygen Scientific warranty. Contact your local Axygen International Distributor or Warranty Card for more details.

For research use only. Not intended for any animal or human therapeutic or diagnostic use.

Axygen recommends that you record the details of your purchase in the spaces below for your future reference.

Model Number	
Serial Number	
Date Purchased/ Received for use	
Purchase Reference Number	
Purchased From	



33210 Central Avenue, Union City, CA 94587, USA
Tel: +510-494-8900 Fax: +510-494-0700
E-mail: axgsales@corning.com
Web Site: www.axygen.com