

-86°C Ultra Low Temperature Upright Freezer Instruction Manual

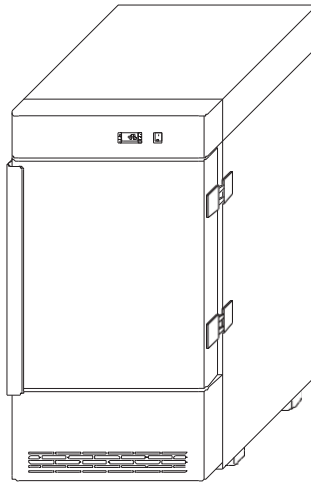

Model number:
CMF86V80

For Customer Services & Spare Parts please call **0161 772 5666**
Opening times: Monday - Friday 9am – 4pm
or visit us at www.coolmed.co.uk

**IMPORTANT:
RETAIN FOR FUTURE REFERENCE**

Contents

Safety Instructions	3-4
Electrical Safety	4
Transportation & Handling	5
Installing & Switching on your Appliance	5
Before Switching On	6
Product Overview	7
Usage	8-9
Remote Alarm	10
Defrosting	11
Energy Saving Advice	12
Maintenance & Cleaning	13
Trouble Shooting	14-15
Connection to the Mains Supply	16
Guarantee	17
Technical Specification	18
Notes	19



For Customer Services & Spare Parts please call

Opening times: Monday - Friday 8am - 5pm

or visit us at www.coolmed.co.uk

Safety Instructions

Important note: Please read this booklet before installing and switching on this appliance. The manufacturer assumes no responsibility for incorrect installation and usage as described in this booklet.

- This model uses natural refrigerant gas as part of its cooling system. This gas is environmentally friendly but can be combustible. Care should therefore be taken when handling or transporting the product to ensure that none of the refrigeration circuit components are damaged.
- Do not obstruct ventilation openings in the appliance.
- The appliance must not be placed or rested on its power cord.
- Do not use mechanical devices or other artificial means to accelerate the defrosting process, such as a heater or a hair dryer.
- Do not use electrical appliances in the refrigerator compartment of the appliance.
- If this appliance is to replace an old refrigerator with a lock, the lock must be removed as a safety measure before storing it or disposing of it. This is to protect children from locking themselves inside the appliance.
- Old refrigerators and freezers contain insulation gases and refrigerant, they must be disposed of properly. Contact your local authority or your dealer if you have any questions. Please ensure that you do not damage the scrap unit prior to being picked-up by the relevant waste disposal service.
- Do not use adaptors or extension leads when connecting the appliance to the electrical power supply.
- Do not plug in if the plug or mains cable is damaged.
- Do not pull, twist or damage the power cable.
- Do not plug-in or un-plug the appliance with wet hands to prevent electrical shock.



For Customer Services & Spare Parts please call
Opening times: Monday - Friday 8am - 5pm
or visit us at www.coolmed.co.uk

- This appliance is designed to be used by adults, do not allow children to play with the appliance or let them hang over the door.
- Do not place explosive or flammable material in your appliance for your own safety.
- Bottles containing a high percentage of alcohol must be sealed well and placed vertically in the refrigerator.
- Do not cover the body or the top of the appliance
- Do not position the freezer next to a heat source or in direct sunlight.
- The freezer cabinet should not be placed directly against the wall keep at least 10cm gap from rear of the freezer to the wall.
- Fix down the accessories in the appliance during transportation to prevent damage to them.

Electrical Safety

THIS APPLIANCE MUST BE PLUGGED INTO AN EARTHED SOCKET

- Before switching on, make sure that the voltage of your electricity supply is the same as that indicated on the rating plate. This product is designed to operate on 230 – 240V AC; 50Hz. Connection to any other power source may damage the unit.
- This product may be fitted with a non re-wireable plug. If it is necessary to change the fuse in the plug, the fuse cover must be refitted. If the fuse cover becomes lost or damaged, the plug must not be used until a suitable replacement is obtained.
- If the plug has to be changed because it is not suitable for your socket, or becomes damaged in any way, it should be cut off and an appropriate plug fitted following the wiring instructions on page 17. This should be carried out by a qualified electrician. The plug removed must be disposed of safely, as insertion into a 13 Amp socket is likely to cause an electrical hazard.



For Customer Services & Spare Parts please call
Opening times: Monday - Friday 8am - 5pm
or visit us at www.coolmed.co.uk

Transportation and Handling

For safe lifting, tilt the appliance backwards by no more than 45 degrees, hold the base and rear corners of cabinet. Lift the refrigerator carefully. Never use the door handles for lifting. To move the refrigerator on a flat level surface, tilt it slightly backwards and push backwards.

This unit is heavy and could cause injury – ensure there is adequate people present to move the appliance.

Installing and Switching on Your Appliance

- Operating voltage for your appliance is 230-240V at 50Hz.
- Before plugging in the power supply, ensure that the voltage on the rating label corresponds to the working voltage of your electrical system in your home.
- Insert the plug into an efficient Ground (Earth) connection. If the socket has no Ground (Earth) contact or the plug does not match, we suggest you call an authorised electrician for assistance.
- Place your appliance in an area that is not exposed to direct sunlight.
- Your appliance should be placed at least 10cm away from stoves, ovens and other heating cores.
- This appliance should never be used outdoors or left in the rain.
- When your appliance is placed next to a chest freezer or freezer, there should be at least 10cms between them to prevent humidity on the outer surface.
- Do not place anything on your appliance and install the unit in a suitable place so that there is at least 30cm clearance above the appliance.
- If placing your appliance next to cabinets, leave 5cm between them.
- The rear of the appliance should be at least 10cm away from the back wall.
- The appliance must be used in the vertical position and on a flat level surface.



For Customer Services & Spare Parts please call
Opening times: Monday - Friday 8am - 5pm
or visit us at www.coolmed.co.uk

- Choose a dry and well-ventilated space.
- The appliance should be positioned so that the plug is easily accessible.
- If you need help or are unsure how to install the unit, please contact Customer Services on **0161 772 5666** or visit www.coolmed.co.uk

Before Switching On

- Before using your appliance, add a teaspoon of bicarbonate of soda to warm water and with a damp cloth wipe down all parts of the new appliance, then repeat the process with a clean damp cloth and dry. **(ensure the appliance is not connected to the power when performing this task).**
- Remove all transport tapes and foam protection pieces . Clean the interior with a cloth dampened in lukewarm soap and water. Wipe with clean water and wipe dry.
- There may be an odour when you first switch on the appliance, it will disappear when the appliance starts to cool.
- When the appliance has been positioned, press the lock on the wheel underneath to stop the freezer from moving.
- Connect to the electrical socket but do not switch the power to the refrigerator on for at least 3 hours. The coolant within the product needs time to settle after it has been transported and put in to position, failure to do this will affect the cooling performance of your appliance.
- Once the appliance has settled run the freezer empty to begin with. After the desired temperature has been reached it can be loaded.
- You may hear faint gurgling or bubbling sounds when the refrigerant is pumped to the cooling system and through the coils or tubing at the rear of the appliance. When the compressor is in operation you may hear a slight whirring sound or pulsating noise. The thermostat controls the operation of the compressor, and you may hear a slight click as it cycles in and out (this is normal).
- To save energy, you should minimize the frequency and duration of door opening.
- Close the door tightly with the door clamp otherwise the normal operation of the freezer will be affected.



For Customer Services & Spare Parts please call
Opening times: Monday - Friday 8am – 5pm
or visit us at www.coolmed.co.uk

Product Overview

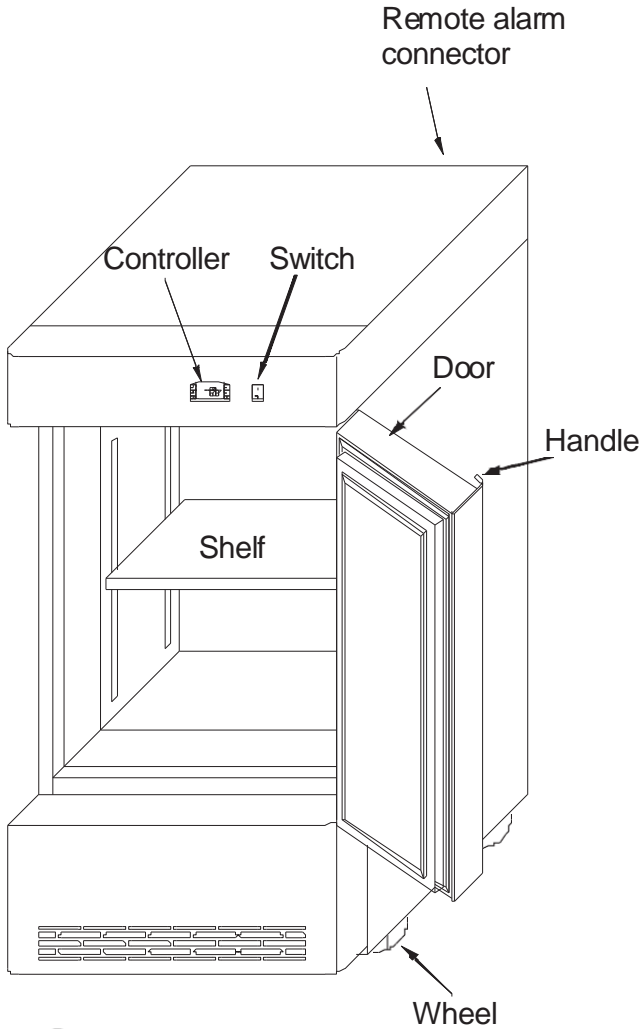

Unit Parts & Spare Parts

Before installation, check that all parts detailed in the product overview are present. If any parts are missing, please contact the Coolmed Customer Service team on **0161 772 5666** or visit us at www.coolmed.co.uk

COOLMED

For Customer Services & Spare Parts please call
Opening times: Monday - Friday 8am – 5pm
or visit us at www.coolmed.co.uk

Usage

! Allow to stand for a minimum of 3 hours before plugging in to the mains

After plug in into the mains socket the freezer will start to freeze after 2minutes.

The temperature in the appliance is controlled by the temperature control panel located outside the freezer. To alter the temperature, press and hold the set button and °C will start to flash, press the up and down buttons to select the desired temperature and press set again. Your temperature now is set and it will take time to reach the set temperature depending on the room temperature. The display will now revert back to the actual temperature in the freezer. The freezer is now running to achieve the desired set temperature .

On the temperature control, pressing down arrow will reduce the temperature and the up arrow will increase the temperature. The temperature range is -70 – -86 Degrees Celsius



The controller records the Hi and Lo temperature. To view the Hi temperature press once the up arrow the Hi temperature will then be displayed. To view the Lo temperature press once the down arrow the Lo temperature will then be displayed. To reset the Hi and Lo recording press the up button and release and immediately press the set button and hold until **rst** is displayed and starts to flash on the screen.

COOLMED

For Customer Services & Spare Parts please call
Opening times: Monday - Friday 8am – 5pm
or visit us at www.coolmed.co.uk

Usage

Alarm Recovery

Probe alarms "PI" starts seconds after the fault in the related probe; this automatically stops after the probe restarts normal operation. Check connections before replacing the probe.

Temperature alarms "HA", "LA", "HA2" and "LA2" automatically stop as soon as the temperature returns to normal values.

The cause of the rise in temperature should be investigated immediately.

Usually the cause is the door being left open or not being shut fully. This can happen also if the freezer has just been restocked with goods at a higher temperature than the freezer, it is recommended to check the freezer to ensure the freezer is returning to the normal temperature after the alarm has been activated.

Alarms "EA" and "CA" (with iLF=bAL) recovers as soon as the digital input is disabled.

Alarm "CA" (with iLF=PAL) recovers only by switching off and on the product.

CONTROLLER FUNCTIONING IN CASE OF POWER FAILURE-ONLY IF A BACK UP BATTERY IS CONNECTED

Power failure without temperature alarm

If the controller is connected to the battery, during a power failure :

1. The Alarm Icon is on.
2. The alarm relay is activated .
3. Every 5s the buzzer rings 3 times for 1s.

When a button is pressed the alarm is silenced. It will continue to ring after **30 minutes** time if the power failure keeps on lasting

By pushing the SET key the controller will display the temperature for 5s.

Power failure and temperature alarm

If during a power failure a temperature alarm happens :

1. The alarm icon is on.
2. The alarm starts ringing continuously.
3. The displays show: Real temperature for 1s, . Alarm label for 1s, and remains off for 5s

The first time a button is pushed the alarm is silenced for **30 minutes**.



For Customer Services & Spare Parts please call

Opening times: Monday - Friday 8am – 5pm

or visit us at www.coolmed.co.uk

Remote Alarm

In the event of a low, high temperature or door alarm the alarm can be connected remotely to the red alarm connector at the back.

Note: the maximum rating for this connection is 1A 30Vdc

In the event of a low, high temperature or other alarm, the alarm can be connected remotely to the connector at the back.

DO NOT CONNECT TO MAINS VOLTAGE

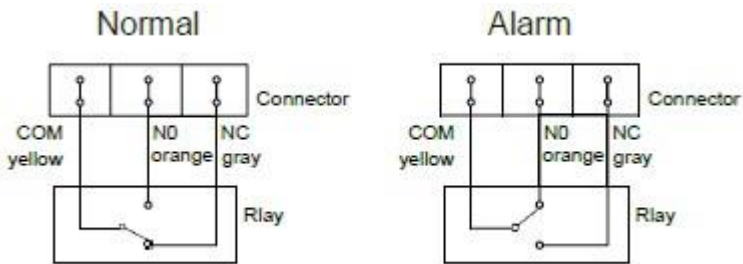

For Customer Services & Spare Parts please call

Opening times: Monday - Friday 8am – 5pm

or visit us at www.coolmed.co.uk

Defrosting

Ice will build up on the evaporator / freezer, this may become excessive during high periods of climatic humidity. This can also happen due to the door being left open or excessively opened, moist items being placed in the freezer, or too low an operating temperature. Ice build up may impair the products performance and a manual defrost should be performed. Ensure all goods from the freezer are transferred to another freezer prior to defrosting.

On a freezer when there is excessive ice build up then a manual defrost must be performed to ensure the freezer operates as normal. Ensure all goods from the freezer are transferred to another freezer prior to defrosting

Defrost by pressing and holding DEF until the defrost symbol illuminates in the control panel.

Once all ice has defrosted wipe dry and the defrost can be deactivated by pressing DEF until the defrost light is not illuminated.

Note: Do not use other mechanical or other means to defrost the freezer as this can cause damage to the appliance and invalidate the warranty



For Customer Services & Spare Parts please call
Opening times: Monday - Friday 8am – 5pm
or visit us at www.coolmed.co.uk

Energy Saving Advice

- Do not install the appliance close to sources of heat, such as a cooker, dishwasher, direct sunlight or radiator.
- Locate the appliance in a cool well-ventilated room and make sure that the air vents are clear.
- Try to avoid keeping the doors open for a long time, warm air will enter the cabinet and may cause a build-up of ice as well as affecting the energy consumption. Ensure there are no obstructions preventing the doors from closing properly.
- Ensure that the door seals are clean and there are no tears or splits.
- Do not overload the appliance: the cooling air that circulates to keep the appliance cold gets blocked and pockets of warm air form.
- Do not put hot items into the freezer – let it cool down first.



For Customer Services & Spare Parts please call

Opening times: Monday - Friday 8am – 5pm

or visit us at www.coolmed.co.uk

Maintenance & Cleaning

Disconnect the appliance from the power supply before cleaning.

Internal Cleaning

- Do not pour water over the appliance.
- The cavity should be cleaned periodically using a solution of bicarbonate of soda and lukewarm water (5ml to 0.5 litre of water)
- Clean the accessories separately with soap and water. Do not put them in the dishwasher.
- Do not use abrasive products, detergents or soaps.
- After washing, rinse with clean water and dry carefully.
- When you have finished cleaning reconnect the plug with **dry hands**.

External Cleaning

- Wash the outer cabinet with warm soapy water. Do NOT use abrasive products.
- There are sharp edges on the underside of the product so care should be taken when cleaning.
- Once or twice a year dust the rear of the appliance and the compressor at the back of the appliance, with a brush or vacuum cleaner, as an accumulation of dust will affect the performance of the appliance and cause increased energy consumption.

When the appliance is not in use

When the appliance is not in use for long periods, disconnect from the electricity supply, empty all of the contents from the freezer and clean the inside. Leave the door open to prevent the build-up of odours.



For Customer Services & Spare Parts please call
Opening times: Monday - Friday 8am – 5pm
or visit us at www.coolmed.co.uk

Trouble shooting

Problem	Solution
The freezer doesn't work	Check that the appliance is switched on.
	Check that there has not been a power cut.
	Check that the plug is not faulty.
	Check that the fuse has not blown.
	Check that the voltage is correct for the appliance.
	Are there any faults with the socket? For this purpose, try the plug of your appliance by connecting it to a socket which you are sure is working.
The temperature inside the appliance is not cold enough	Check that there is not too much products in the appliance.
	Check that the temperature is set to a suitable temperature.
	Check that the appliance is not placed in direct sunlight, or too near to a heating source.
	Check that the ambient temperature is within the operation limits of the appliance a maximum of 32 degrees Celsius
	Are the doors of the appliance opened frequently? Once the door is opened, the humidity found in the air in the room enters the appliance, especially if the humidity levels in the room are very high. The more frequently the door is opened in humid conditions the more chance of the build up of moisture.
The temperature within the appliance is too cold.	Increase the working temperature by adjusting the temperature on the temperature controller to a higher setting.
The inner surfaces of the appliance are wet	Caused by condensation - dry the inside of the appliance.
The outer surfaces of the appliance are wet	Caused by condensation - dry the outer of the appliance carefully.



For Customer Services & Spare Parts please call

Opening times: Monday - Friday 8am – 5pm

or visit us at www.coolmed.co.uk

Trouble shooting

Problem	Solution
Smell/odour	<p>Check all the goods in the freezer is in date and correctly packaged. If it isn't then it should be removed immediately or repackaged.</p> <p>Check for spillages on each shelves. You may need to remove the shelves to check that no spillages have settled underneath them. As spillages that have not been cleaned and have been left can cause smells and unwanted odours.</p>
	<p>Check the drainage pipe is not clogged or the drip tray at the back of the appliance is full. The pipe can be cleared by pouring hot water through, but you must ensure the appliance is turned off, the plug is removed from the socket and a jug or bucket is in place to catch the flow of water.</p>
The doors do not close properly	<p>Ensure there are no obstructions preventing door closure.</p>
	<p>Check the door compartments and shelves are correctly in place.</p>
	<p>Check the door seal is not warped or torn.</p>
	<p>Check the appliance is level.</p>
Unusual noises	<p>Check that the appliance is on a flat, level surface and is stable.</p>
	<p>Check the spacing's around the appliance and ensure it is not touching other items.</p>
	<p>Bubbling and gurgling sound: • This noise is emitted as the coolant fluid flows through the pipes within the system. This is normal.</p>
	<p>Water flowing sound: • This is the normal sound of water flowing into the drain trough during the defrosting process.</p>
	<p>If the appliance is operating noisily (compressor noise): This is normal. This noise indicates that the compressor is operating normally. As the compressor is being energized, it might run a bit more noisily for a short period of time.</p>



For Customer Services & Spare Parts please call

Opening times: Monday - Friday 8am – 5pm

or visit us at www.coolmed.co.uk

Connection to the Mains Supply

WARNING- THIS APPLIANCE MUST BE EARTHED

This appliance is designed to operate from a mains supply of AC230V - 240V; 50HZ. Check that the voltage marked on the product corresponds with your supply voltage.

For UK use only – Plug fitting details (where applicable):

As the colours of the wires in the mains lead of this appliance may not correspond with the coloured markings identifying the terminals in your plug, proceed as follows:

The GREEN/YELLOW wire is the EARTH and must be connected to the terminal which is marked with the letter E or by the earth symbol or coloured GREEN or GREEN/YELLOW.

The BLUE wire is the NEUTRAL and must be connected to the terminal marked with the letter N or coloured BLACK.

The BROWN wire is the LIVE wire and must be connected to the terminal marked with the letter L or coloured RED.

Always ensure that the plug cord grip is fastened correctly.

If a 13A (BS1363) fused plug is used it must be fitted with a 13amp fuse conforming to BS1362 and be BSI or ASTA approved.



**DANGER
Electric
Shock Risk**

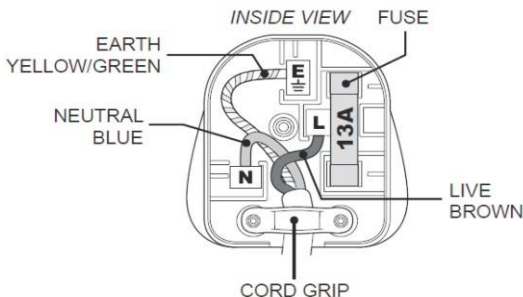

COOLMED

For Customer Services & Spare Parts please call

Opening times: Monday - Friday 8am – 5pm

or visit us at www.coolmed.co.uk

Guarantee

This product is guaranteed for 24 months from the date of the original purchase.

If any defect arises due to faulty materials or workmanship you must contact Coolmed with the original proof of purchase so a replacement or refund can be arranged.

Refund or replacement is at the discretion of Coolmed.

The following conditions apply:

- Coolmed will require a valid proof of purchase at the point of replacement or refund.
- The product must be installed and used in accordance with the instructions contained in this instruction guide and any other instructions for use which has been supplied.
- It must be used for domestic purposes only and for its intended use.
- This guarantee does not cover wear and tear, damage, misuse or consumable parts.

This does not affect your statutory rights.

COOLMED LIMITED
Manchester
M17 1SW



For Customer Services & Spare Parts please call
Opening times: Monday - Friday 8am – 5pm
or visit us at www.coolmed.co.uk

Technical Specification

Model number	CMF86V80
Rated Voltage	220V – 240V ~ 50Hz
Capacity	80L
External Dimensions(HxWxD)	1260mm x 650mm x 1260mm



For Customer Services & Spare Parts please call
Opening times: Monday - Friday 8am – 5pm
or visit us at www.coolmed.co.uk

Notes



For Customer Services & Spare Parts please call
Opening times: Monday - Friday 8am – 5pm
or visit us at www.coolmed.co.uk

For Customer Services &
Spare Parts please call

COOLMED

Opening times:

Monday- Friday

8am-5pm

or visit us at

www.coolmed.co.uk



This symbol is known as the 'Crossed-out wheeie bin Symbol'. When this symbol is marked on a product/batteries, it means that the product/batteries should not be disposed of with your general household waste. Only discard electrical/electronic/battery items in separate collection schemes, which cater for the recovery and recycling of materials contained within. Your co-operation is vital to make sure the success of these schemes and for the protection of the environment. For your nearest disposal facilit¼ visit www.recycle-more.co.uk or ask in store for details.

We reserve the right due to possible changes to design to alter the instruction manual without prior notice.

COOLMED[®]
COMMERCIAL

Revision 3